



Georgia  
FCCLA  
Competitive  
Events  
Workshop

---

July 14, 2019

# Why participate in our various competitive events?

---

- Real world experience
- Technical skill development
- Incorporate into classroom and chapter activities
- Events are directly aligned to our standards
- <https://gactso.org/competitive-events>
- Extended day requirements (CTAERN Program of Work)



# Competitive Events and Conferences... What is available?

---

- Fall Rally
- Fall Leadership Conference
- National Fall Conference
- Day at the Capitol
- Online Proficiency Testing
- State Events at the State Leadership Conference
- STAR Events

# Fall Rally Competitions

---

October 2019



# Fall Rally Competitions

---

## **NEW POLICY THIS YEAR**

Chapters must be registered for the Fall Rally (through Georgia FCCLA) in order to participate in any Fall Rally Competitive Events

# Fall Rally Competitions

---

## **Events Ran Through Georgia National Fair**

- Brochure Event
- Chapter Fair Booth
- Chili Cook Off
- Culinary Competition
- Knowledge Bowl (Final Round)
- Peanut Recipe Competition

## **Events Ran Through Georgia FCCLA**

- Georgia Organics Event
- Knowledge Bowl (Online Testing Round)

# Fall Rally Competitions Tips and Tricks

---

## Registering Through the Fair

- Passwords must be requested by **September 16, 2019**
- Email [contests@gnfa.com](mailto:contests@gnfa.com) or call 1-800-987-3247, ext. 555
- **What they will need from you:**
  - Chapter name
  - School address
  - School phone number
  - Adviser name
  - Adviser email address

# Fall Rally Competitions Tips and Tricks

---

## Registering Through the Fair

- Registration deadline is **September 18, 2019**
- Enter online at  
<https://www.georgianationalfair.com/p/georgialiving/youth>
- Substitutions are NOT allowed
- Late entries will not be processed



# Fall Rally Competitions Tips and Tricks

---

## **Registering Through the Fair**

- Chapter events must be entered in the chapter's name
  - Brochure Event
  - Chapter Fair Booth
  - Knowledge Bowl
- Individual events must be entered in the individual's (member's) name
  - Chili Cook-Off
  - Culinary Competition
  - Peanut Recipe



# Fall Rally Competitions Tips and Tricks

---

## Brochure Event

- Chapter event – register in chapter's name
- Two divisions – Middle School and High School
- Four classes (options) – chapters can only pick **ONE**
  - Male Recruitment
  - One National Program or State Program
  - Alumni & Associates Recruitment
  - General FCCLA Information

# Fall Rally Competitions Tips and Tricks

---

## **Brochure Event**

- Original work of chapter or chapter member
- NEW THIS YEAR!!! Brochures are to be submitted online
  - Deadline September 20, 2019
  - <https://gafccla.wufoo.com/forms/2019-fall-rally-brochure-competition-submission/>
  - Must be submitted in PDF format

# Fall Rally Competitions Tips and Tricks

---

## **Chapter Fair Booth**

- Chapter Event – must be registered in chapter's name
- Two divisions – Middle School and High School
- Display Set Up
  - September 25-28, 2019
  - Weekdays 9:00 am – 5:00 pm
  - Saturday 10:00 am – 3:00 pm
  - Only one day – return trips to modify or complete is not allowed



# Fall Rally Competitions Tips and Tricks

---

## **Chapter Fair Booth**

- Booth must be based on the current state or national programs
- Panels are supplied by the fair
- Decorations must be stapled or thumbtacked – cannot use glue or paint
- Chapters are encouraged to pre-make displays that can slide into booth



# Fall Rally Competitions Tips and Tricks

---

## **Chapter Fair Booth**

- No more than 5 students can help set up (with adviser)
- Electricity is available
- Display take down - October 15-16 or October 19
- Cancellations – please call the fair!

# Fall Rally Competitions Tips and Tricks

---

Chapter Booth Dimensions

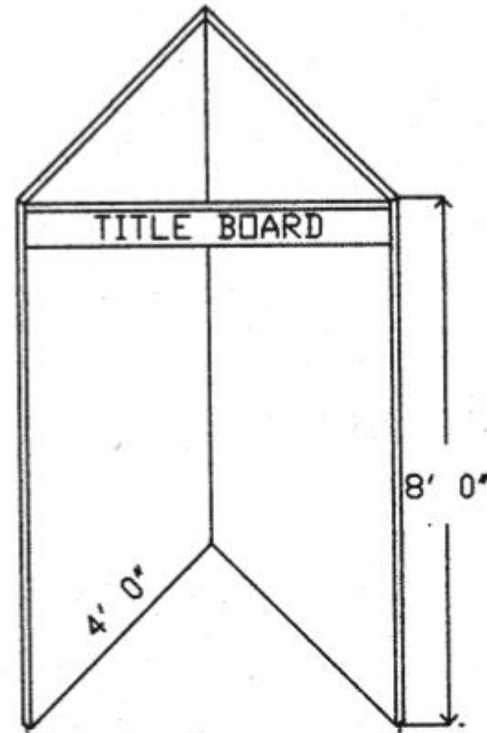

Approximate  
Measurements





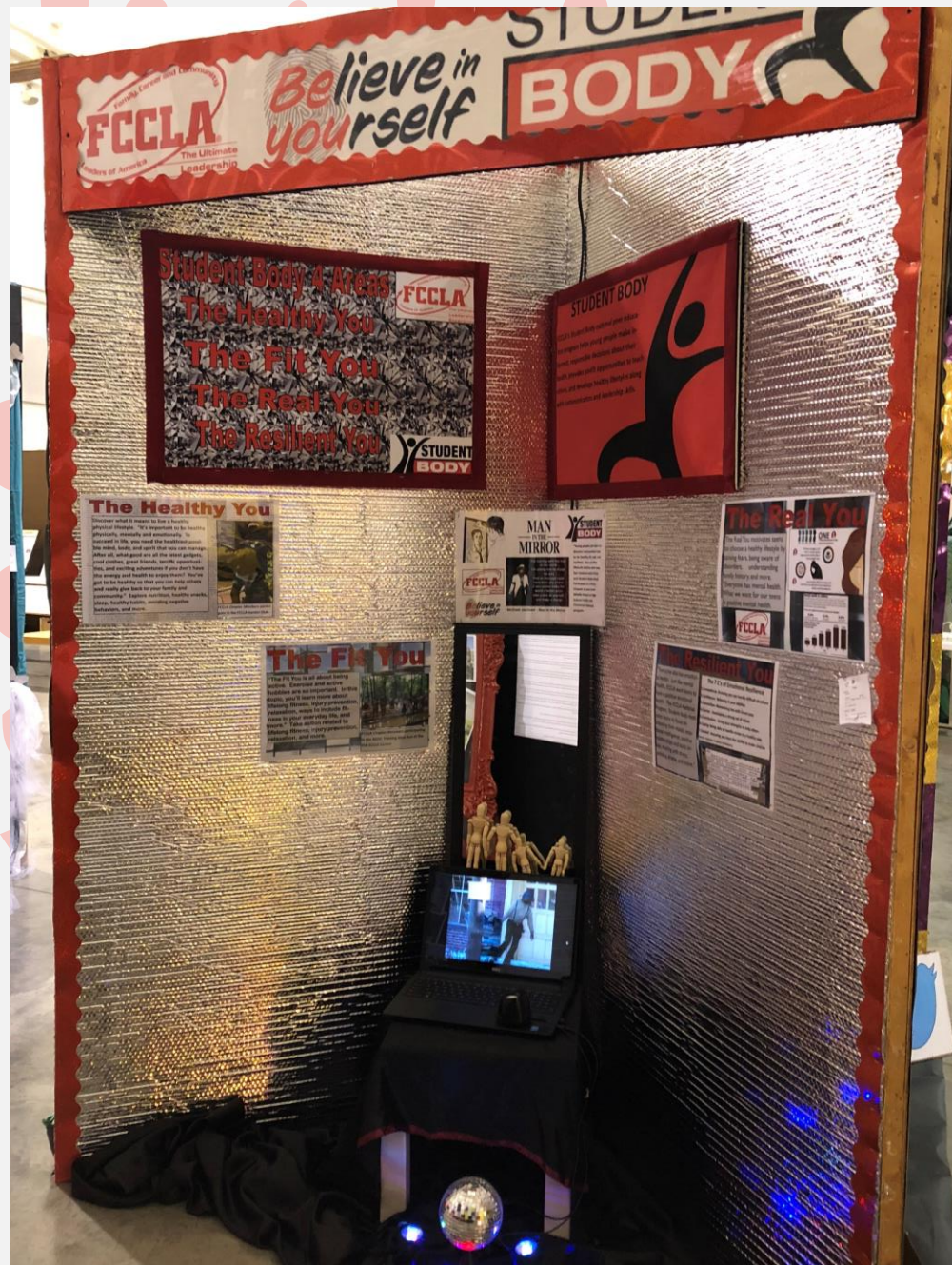

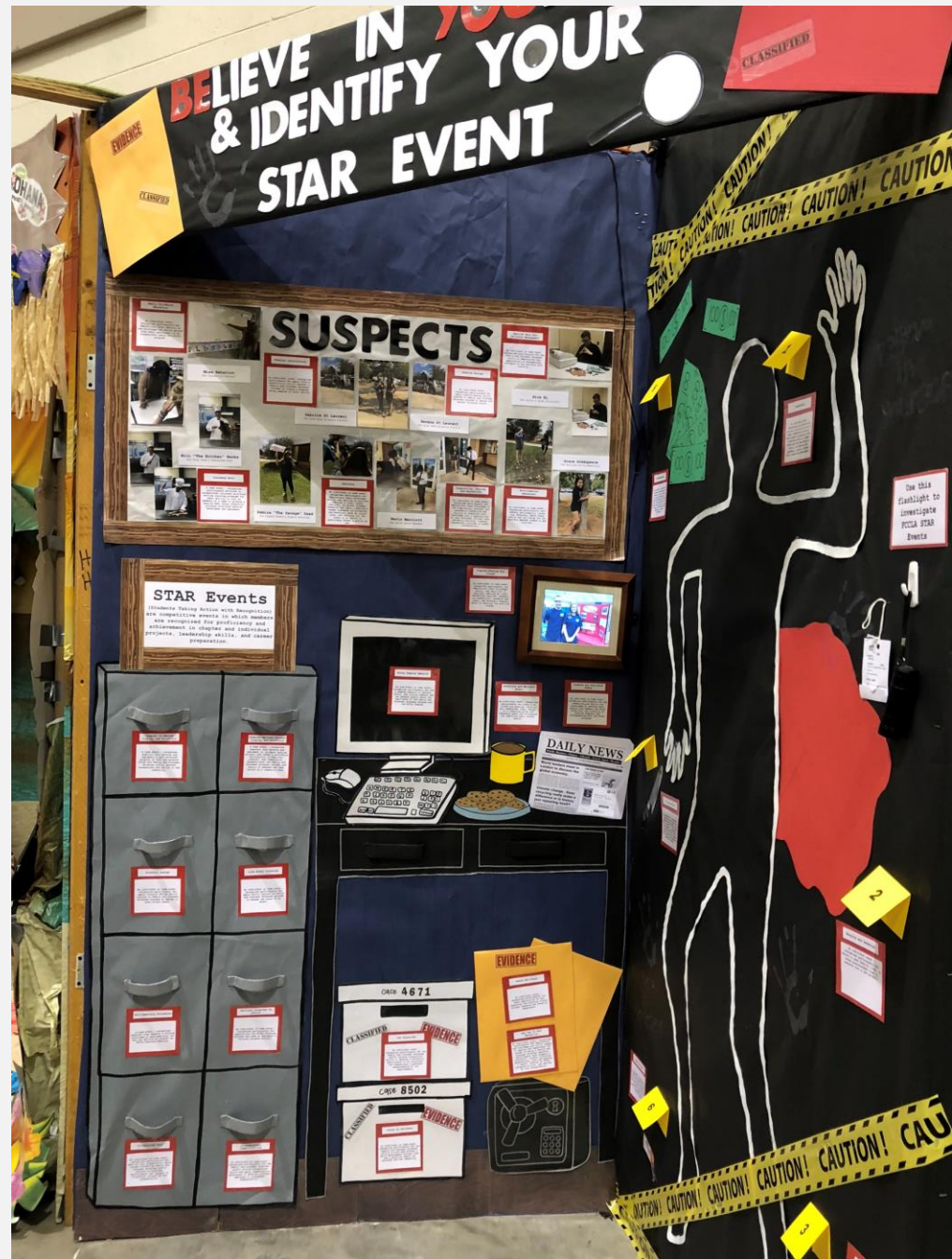



# Fall Rally Competitions

## Tips and Tricks

---

### **Chili Cook Off**

- Individual event – must be registered in member's name
- Two divisions – Middle School and High School
- Only 20 participants will be allowed – more than that and a lottery drawing will determine the 20 participants
- Participants supply ingredients and cooking equipment
- Preparation is done from scratch – no chili mixes



# Fall Rally Competitions Tips and Tricks

---

## **Chili Cook Off**

- Teacher/adult can help move equipment, but cannot coach student
- Pay specific attention to food requirements

# Fall Rally Competitions

## Tips and Tricks

---

### **Peanut Recipe Competition**

- Individual event – must be entered in member's name
- Three divisions:
  - Middle School
  - Junior (Grades 9-10)
  - Senior (Grades 11-12)
- One entry per division
- Only 30 participants per division – lottery drawing if needed

# Fall Rally Competitions Tips and Tricks

---

## **Peanut Recipe Competition**

- **Product type for 2019 – Dessert item**
- Bring with you:
  - Three ready-made servings on separate plates
  - Three copies of recipe on 4x6 index card

# Fall Rally Competitions

## Tips and Tricks

---

### **Culinary Competition**

- Individual event – must be entered in member's name
- Only for culinary students
- Only 10 participants, lottery drawing if need
- Judged on knife skills and preparation of “hot plated meal” – chicken breast (provided), starch, vegetable
- Pay close attention to food requirements

# Fall Rally Competitions Tips and Tricks

---

## **Knowledge Bowl**

- Chapter Event – enter in chapter's name
- Three divisions:
  - Culinary & FCCLA
  - High School FACS & FCCLA
  - Middle School & FCCLA
- Also register through Georgia FCCLA in the Fall Rally Registration System
  - Names of participants needed
  - Proctor name and email address needed



# Fall Rally Competitions Tips and Tricks

---

## **Knowledge Bowl – Qualification Testing**

- Takes place September 23-27, 2019
- Proctors emailed information
- Must have four FCCLA members
- 50 question test
- Test only contains content question, no FCCLA questions
- Questions WILL NOT match study guide
- Top 16 teams will advance to final round



# Fall Rally Competitions Tips and Tricks

---

## **Knowledge Bowl – Buzzer Rounds**

- Head-to-head questions
- Team questions
- Single elimination
- Questions come from study guide

# Fall Rally Competitions Tips and Tricks

---

## **Georgia Organics – Oh My Squash! Competition**

- Only competition NOT ran through Georgia National Fair
- Sign up on Georgia Organics website to receive electronic resources
- Plan school activities by using resources
- Implement activity and post to social media
- Submit information to Wufoo form
- Entries are judged by Georgia Organics

Fall Leadership  
Conference  
Competitions

November 2019



# Fall Leadership Conference Competitions

---

## **NEW POLICY THIS YEAR**

Chapters must be registered for the Fall Leadership Conference (through Georgia FCCLA) in order to participate in any Fall Leadership Conference Competitive Events

The slide features a decorative background with various sizes of pink circles scattered across the left and bottom edges. A solid red horizontal line is positioned below the main title.

# Fall Leadership Conference Competitions

- Membership Recruitment Display
- Pin Design
- T-Shirt Design
- Statesman and Distinguished Statesman Tests

# Fall Leadership Conference Competitions Tips and Tricks

---

## **Membership Recruitment Display**

- Based on membership recruitment techniques
- Table top or floor displays
- NO electricity provided
- Judged onsite - Judging based on:
  - Increasing awareness of FCCLA
  - Recruitment effectiveness
  - Display appearance and organization
  - Recruitment uniqueness







# Fall Leadership Conference Competitions Tips and Tricks

---

## **Pin Design Competition**

- Submitted as a PDF ahead of time
- Must be original artwork
- Use characteristics unique to Georgia (no trademarked or copyrighted material)
- 6 colors only (including black and white)
- Top entries on display and voted on by chapters at FLC



The star over the dot in the "I" in Georgia represents a light to resemble Atlanta, the capitol of Georgia.



# Fall Leadership Conference Competitions

## Tips and Tricks

---

### **T-Shirt Design Competition**

- Submitted as a PDF ahead of time
- Must be original artwork
- Must use national theme – Your Story
- Chapter name and FCCLA logo must be on shirt (used correctly)
- No trademarked or copyrighted material
- Top entries to be voted on by chapters



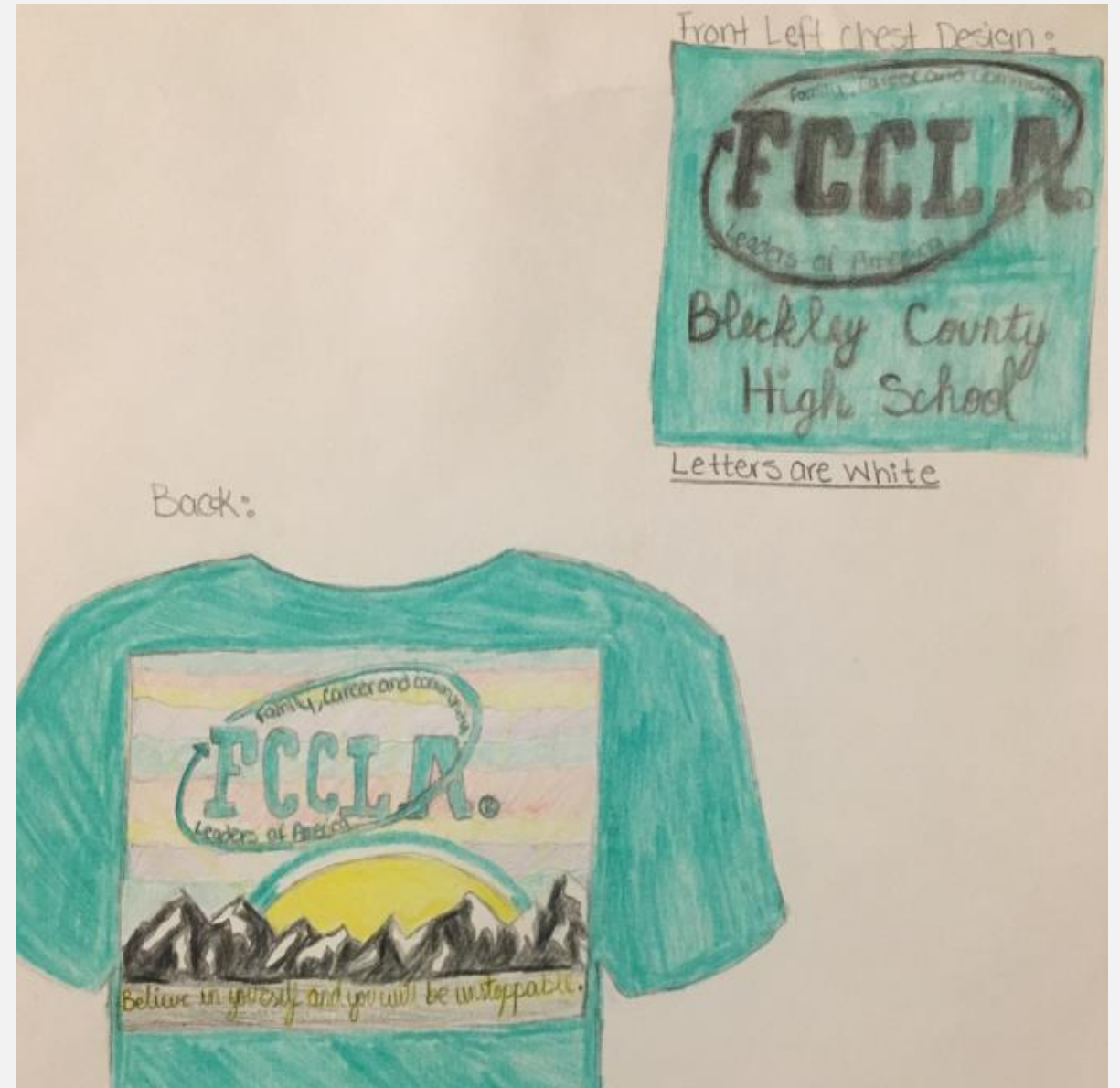
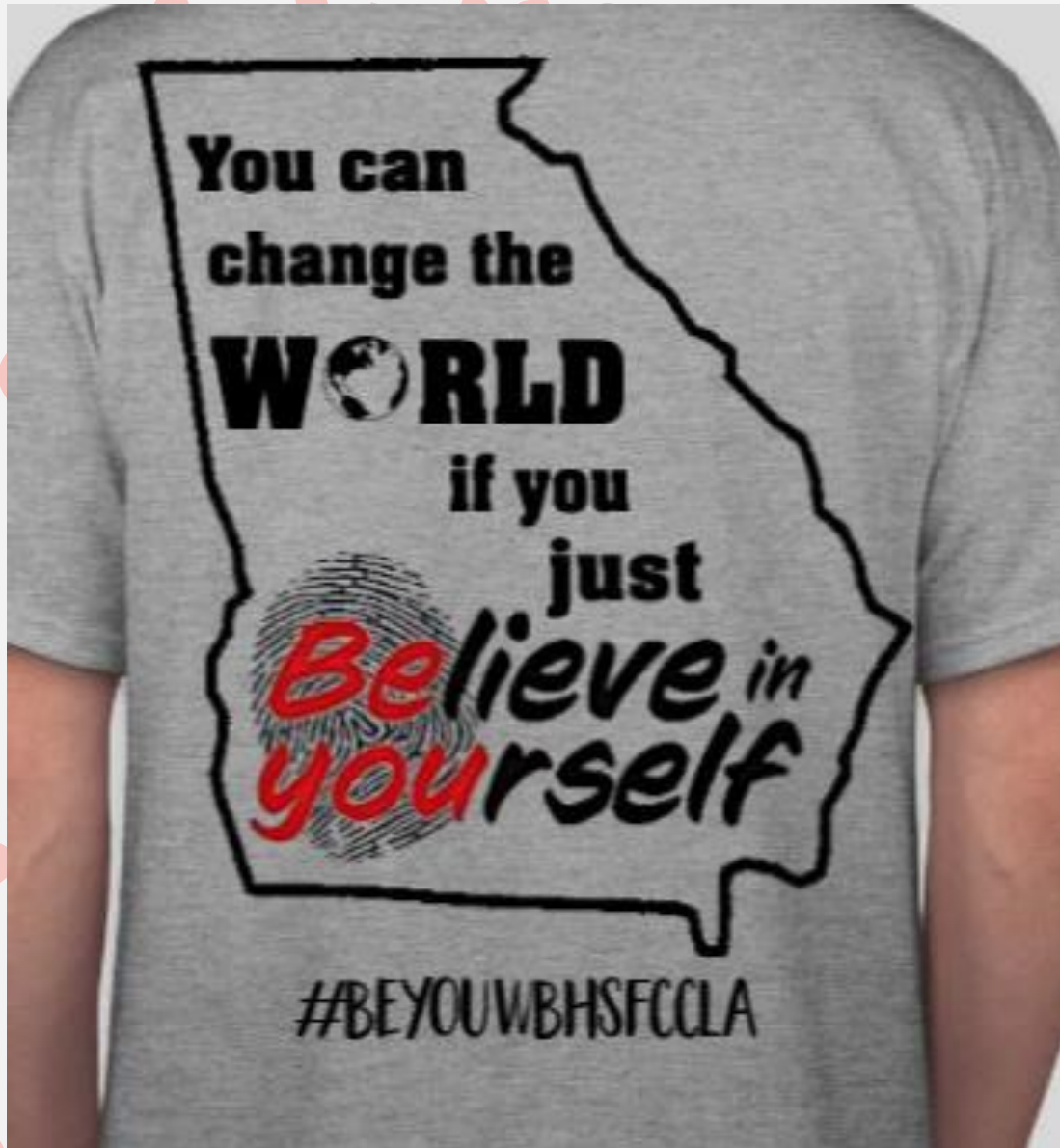

# Fall Leadership Conference Competitions

## Tips and Tricks

---

### **Statesman Test**

- FCCLA knowledge-based test
- \$5 registration fee
- Study guide provided – questions come directly from study guide
- 50 multiple choice questions
- Scantron and pencils provided
- Must make an 85% to be awarded Statesman

# Fall Leadership Conference Competitions Tips and Tricks

---

## **Distinguished Statesman Test**

- For members who have previously passed the Statesman test (with an 85% or higher)
- 50 multiple choice questions
- Also contains a written component
- Must make an 85% or higher to receive Distinguished Statesman



National Fall  
Conference  
Competitions

November 2019



# National Fall Conference Competitions

---

- Must be registered for the 2019 National Fall Conference in Dallas, Texas
- Guidelines will come out in the fall inside the 2019-2020 Competitive Events Guide (located in your FCCLA Portal)

# National Fall Conference Competitions

---

## **Anticipated onsite competitions in 2019:**

- Culinary Knife Skills
- Fashion Sketch
- FCCLA Creed Speaking & Interpretation
- Impromptu Speaking
- Pastry Arts Technical Decorating Skills
- Speak Out for FCCLA
- Technology in Teaching



# National Fall Conference Competitions

---

## **Anticipated online testing competitions in 2019:**

- Consumer Math Challenge
- Culinary Math Challenge
- Early Childhood Challenge
- Fashion Construction and Design Challenge
- FCCLA Knowledge Challenge
- Hospitality, Tourism and Recreation Challenge
- Interior Design Challenge
- Nutrition Challenge
- Science in FCS Challenge

# Day at the Capitol Competition

---

February 2020

# Day at the Capitol Competitions

---

## **Legislative Leaflet Competition**

- Chapters design a leaflet (“leave behind”) to share the chapter’s FCCLA story in photos and data
- Can be a tri-fold, duo-fold, or a flyer
- Limited to one sheet of paper
- Submitted prior to Day at the Capitol

# Online Proficiency Testing

---

February 2020

# Online Proficiency Tests Available

---

- Consumer Services
- Culinary Arts
- Early Childhood Education
- Etiquette
- Fashion Design
- Hospitality
- Interior Design
- Middle School: Family and Consumer Sciences
- Nutrition and Food Science
- Parliamentary Procedure
- Teaching as a Profession





# Online Proficiency Tests

## Tips and Tricks

---

- Tests a member's knowledge in a specific FCS area
- Top 3 in each test will be recognized onstage at the 2020 State Leadership Conference
- Members can only take one test each year
- Members taking the same test must take it at the same time, if not – it leads to disqualification



# Online Proficiency Tests Tips and Tricks

---

- Must have a non-FCS/FCCLA proctor
- All testing information is sent to the proctor
- NO STUDY GUIDES ARE PROVIDED
- Test questions are based off classroom standards
- 50 multiple choice questions

# State Events (at SLC)

---

March 2020



# State Events Available

---

- Chicken Fabrication
- Creative Showpiece
- Creed Speaking and Interpretation
- Digital Delish Dish
- Digital Storytelling
- Food Science Investigation
- Knife Skills
- Power of One
- Statesman and Distinguished Statesman
- Toys That Teach

# State Events Tips and Tricks

---

## **Chicken Fabrication**

- Individual event
- Fabricate a chicken (provided) into eight pieces – meeting industry standards
- Must be currently or previously enrolled in a Culinary Arts class
- 10 minutes to set up, 20 minutes to fabricate and present, 10 minutes to clean up

# State Events Tips and Tricks

---

## **Creative Showpiece**

- Individual event
- Use a variety of fruits/vegetables to prepare and display a culinary showpiece
- Must be currently or previously enrolled in a Culinary Arts class
- **Theme for 2020: Georgia Grown Products**
- One-hour time limit – including set up, production, presentation and clean up

# State Events Tips and Tricks

---

## **Creed Speaking & Interpretation**

- Individual event
- Open to all FCCLA members
- Middle school and high school categories
- Chapters can submit up to 3 entries/students
- Recite creed from memory (2 minutes max)
- Answer 3 questions concerning meaning of the creed and how it fits to the participant's personal philosophy

# State Events

## Tips and Tricks

---

### **Digital Delish Dish**

- Individual or team event (1-3 members)
- Open to all FCCLA members
- Middle school and high school event categories
- 1-minute video
- Food demonstration including at least one food science fact and one Georgia grown ingredient





# State Events Tips and Tricks

---

## **Digital Storytelling**

- Individual or partner event (1-2 members)
- Event categories:
  - Middle school – must be enrolled or previously enrolled in a middle school FCS course
  - High school – must be enrolled or previously enrolled in an ECE or TAP class
- 1 ½ - 2-minute video about one ECE or TAP standard

# Why should you read to an infant?

- Prepares for learning later in his/her life
- Baby begins to pick up rhythm, tone, and inflections



# State Events Tips and Tricks

---

## **Food Science Investigation**

- Individual or team event (1-3 members)
- Open to all FCCLA members
- Middle school and high school event categories
- Video up to 3-minutes about food science facts in action



 Acetic Acid = Vinegar

# State Events Tips and Tricks

---

## **Knife Skills**

- Individual event
- Open to culinary students
- 5 knife cuts
- 10 minutes to set up, 50 minutes to produce and arrange knife cuts, and 10 minutes to clean up

# State Events Tips and Tricks

---

## **Power of One**

- Individual event
- Open to all FCCLA members
- No limit on number of competitors per chapter
- Members complete all Power of One units and create a portfolio documenting their five projects
- No placements (1<sup>st</sup>, 2<sup>nd</sup>, 3<sup>rd</sup>, etc.) – all members can receive recognition if they complete all aspects of the rubric

# State Events Tips and Tricks

---

## **Toys That Teach**

- Individual event
- Event categories:
  - Middle school – must be enrolled or previously enrolled in a middle school FCS course
  - High school – must be enrolled or previously enrolled in an ECE or TAP class
- Design, build and demonstrate an original homemade toy that provides learning and play for a child or small group of children



# STAR Event Competitions

---

February - March 2020

# STAR Events

## Updates for 2019-2020

---

### **New Competitive Event Category Structure**

- Level 1 – grades 5 through 8
- Level 2 – grades 9-10
- Level 3 – grades 11-12



# STAR Events

## Updates for 2019-2020

---

### **New Competitive Event Category Structure**

- Mixed teams are still allowed but must compete at the highest level of the teams' members.
- Some events will still have eligibility requirements requiring specific courses or program enrollment

# STAR Events

## Updates for 2019-2020

---

### **New STAR Events**

- Baking and Pastry (Level 3 Only)
- Event Management (Levels 1, 2, and 3) – *takes the place of Life Event Planning*
- Instructional Video Design (Levels 1, 2 and 3) - Online STAR Event

# STAR Events

## Updates for 2019-2020

---

### STAR Event Name Changes

Previous Event Name	New Event Name
Advocacy	Public Policy Advocate
Applied Math for Culinary Management	Culinary Math Management
Environmental Ambassador	Sustainability Challenge
Illustrated Talk	Professional Presentation
Recycling and Redesign	Repurpose and Redesign



# STAR Events

## Updates for 2019-2020

---

### **Events that can now be Individual or Team (1-3 members)**

- Fashion Design
- Repurpose or Redesign
- Nutrition and Wellness

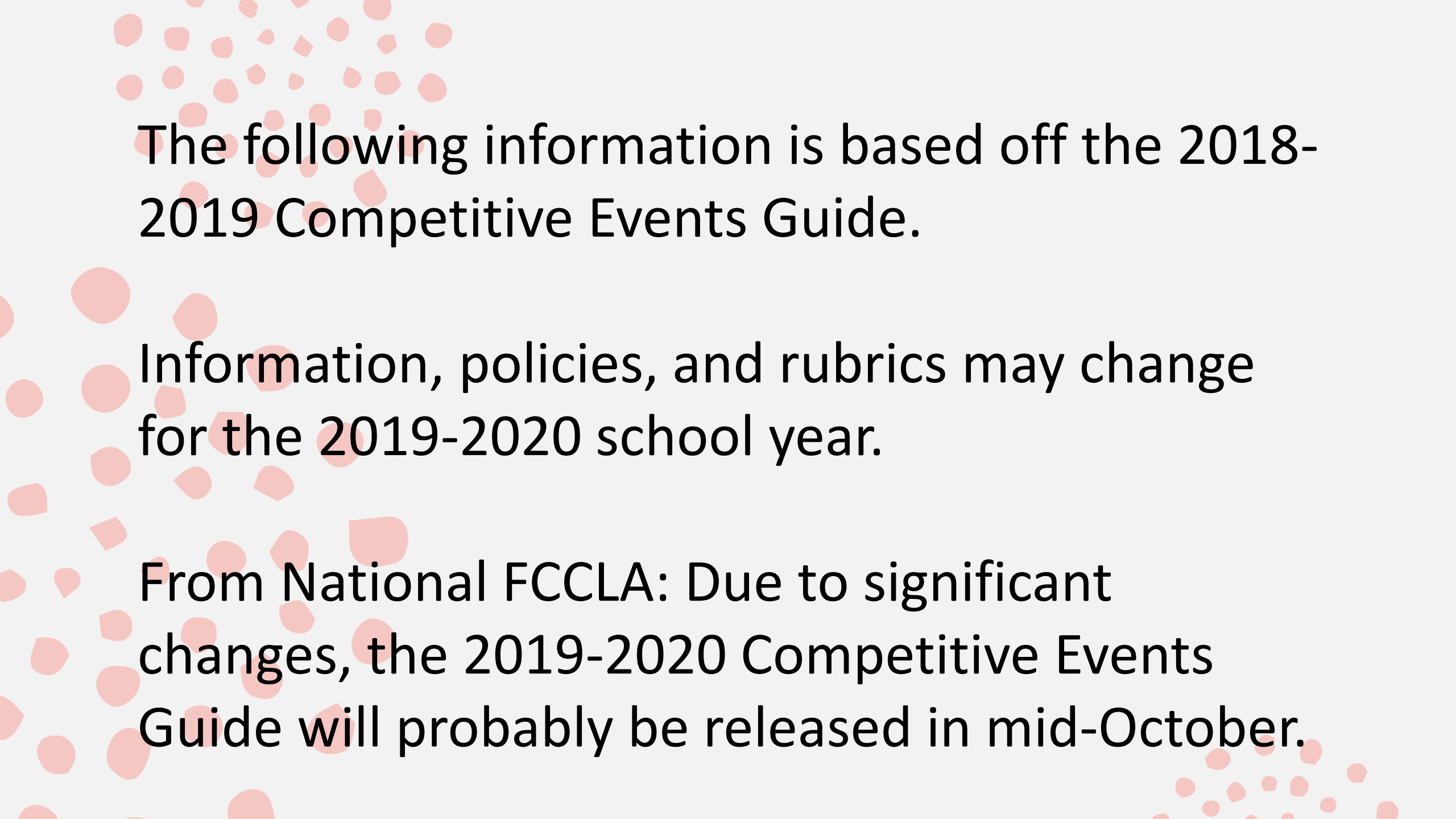

The following information is based off the 2018-2019 Competitive Events Guide.

Information, policies, and rubrics may change for the 2019-2020 school year.

From National FCCLA: Due to significant changes, the 2019-2020 Competitive Events Guide will probably be released in mid-October.



# STAR Events Tips and Tricks

---

## **STAR Events Rubrics**

- Use the “language of the rubric”
- Utilize the FCCLA Planning Process
- Look at what you can and cannot do!



# STAR Events

## Tips and Tricks

---

### STAR Events Rubrics

GENERAL INFORMATION								
Individual or Team Event	Prepare Ahead of Time	Equipment Provided	Electrical Access	Participant Set Up / Prep Time	Room Consultant & Evaluator Review Time	Maximum Oral Presentation Time	Evaluation Interview Time	Total Event Time
Individual or Team	Portfolio, Oral Presentation	Table	Not provided	10 minutes	10 minutes prior to presentation	1-minute warning at 9 minutes; stopped at 10 minutes	5 minutes	30 minutes

PRESENTATION ELEMENTS ALLOWED									
Audio	Costumes	Easel(s)	File Folder	Flip Chart(s)	Portfolio	Props/ Pointers	Skits	Presentation Equipment	Visuals
■		■		■	■	■		■	■

# STAR Events Tips and Tricks

---

## **STAR Events Rubrics**

- Certain events have scenarios that you must follow – listed on the first page of the guidelines
- Make sure you refer back to the FAQs and the Glossary (look for the *italicized* words)



# STAR Events Tips and Tricks

---

## **STAR Events Rubrics – Specific Scenarios**

- Digital Stories for Change (Online Event)
- Early Childhood Education
- Food Innovations
- Interior Design
- Sustainability Challenge (aka... Environmental Ambassador)

# STAR Events

## Tips and Tricks

---

### **STAR Events Rubrics – Specific Resources**

- Chapter in Review (Display & Portfolio)
- Digital Stories for Change
- Early Childhood Education
- Fashion Construction
- Interior Design
- Job Interview
- Leadership
- Life Event Planning
- Parliamentary Procedure
- Teach and Train



# STAR Events Tips and Tricks

---

## **STAR Events Types – Portfolio Events**

- Career Investigation
- Chapter in Review Portfolio
- Chapter Service Project Portfolio
- Early Childhood Education
- Entrepreneurship
- Event Management (aka.... Life Event Planning replacement)
- Fashion Design



# STAR Events Tips and Tricks

---

## **STAR Events Types – Portfolio Events**

- Hospitality, Tourism and Recreation
- Job Interview
- Leadership
- Nutrition and Wellness
- Promote and Publicize FCCLA
- Public Policy Advocate (aka... Advocacy)



# STAR Events Tips and Tricks

---

## **STAR Events Types – Portfolio Events**

- Say Yes to FCS Education
- Sustainability Challenge (aka... Environmental Ambassador)
- Teach and Train

# STAR Events Tips and Tricks

---

## **STAR Events Types – Portfolio Events**

- Must use the official FCCLA STAR Event Portfolio (red or white)

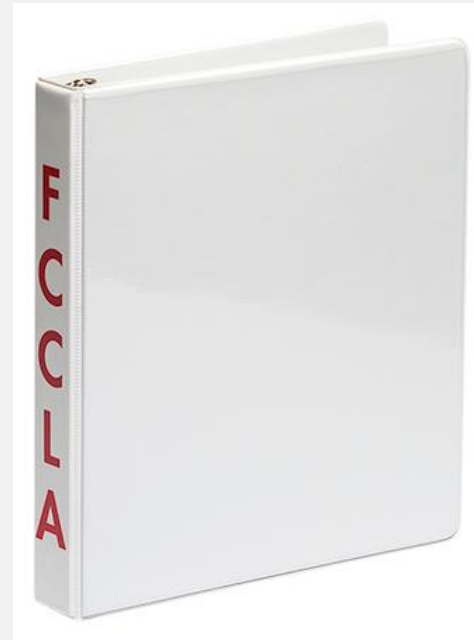
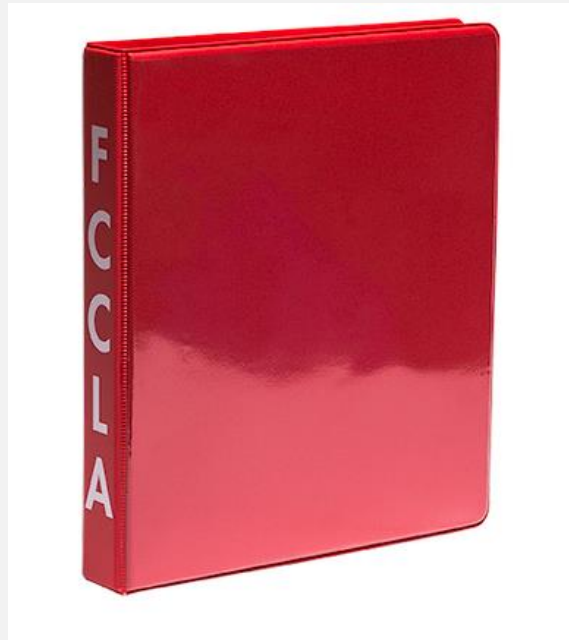



# STAR Events

## Tips and Tricks

---

### **STAR Events Types – Display Events**

- Chapter in Review Display
- Chapter Service Project Display
- Fashion Construction
- Focus on Children
- Food Innovations
- Repurpose and Redesign (aka... Recycle and Redesign)

# STAR Events

## Tips and Tricks

---

### **STAR Events Types – Display Events**

- Displays are measured from the very top (or bottom) of any materials beyond the actual board
- Items within the display may be used as in-hand visuals during the oral presentation; however, they must be returned within the display dimensions when done

# STAR Events

## Tips and Tricks

---

### STAR Events Types – Display Events

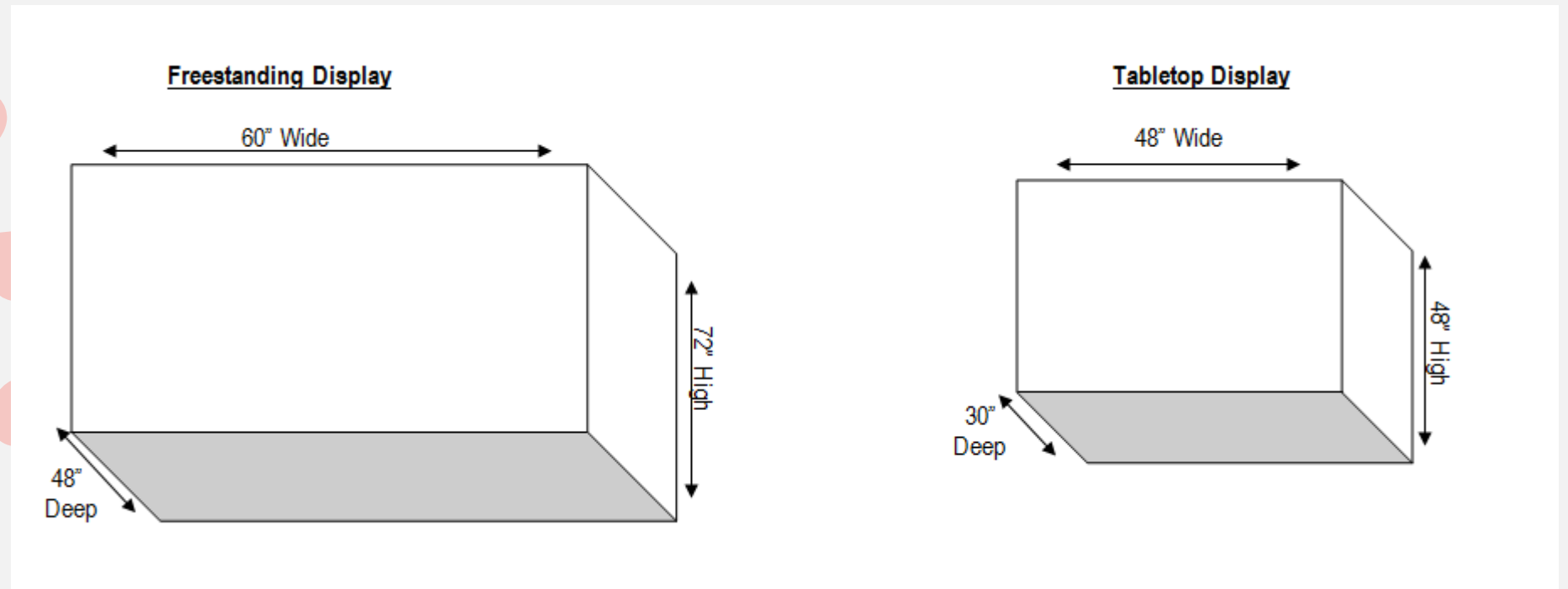



# STAR Events Tips and Tricks

---

## **STAR Events Types – File Folder (with Visuals) Events**

- Culinary Math Management (aka... Applied Math for Culinary Management)
- Interior Design
- Interpersonal Communications
- National Programs in Action
- Professional Presentation (aka... Illustrated Talk)
- Sports Nutrition

# STAR Events

## Tips and Tricks

---

### **Eligibility and General Rules... Often Overlooked**

1. An individual member may participate in only one national STAR Event in any given year. Participation is open to any nationally affiliated FCCLA chapter member. Events may have additional eligibility requirements.
2. Participants must follow national rules for competition, or risk possible disqualification or loss of points.
3. All STAR Events projects must be developed and completed during a one-year span beginning July 1 and ending June 30.

# STAR Events

## Tips and Tricks

---

### Eligibility and General Rules... Often Overlooked

4. All STAR Events projects must be planned and prepared by the **participant(s) only**. Supporting resources are acceptable as long as participants are coordinating their use and resources are cited appropriately verbally and/or in print during the presentation to avoid false credit for unoriginal or non-participant work. Participants are encouraged to use original materials, items licensed for reuse, or items in which copyright permission has been granted.

5. State and chapter advisers should ensure that identical presentations of the same project are not entered into STAR Events multiple years.

# STAR Events

## Tips and Tricks

---

### **Eligibility and General Rules... Often Overlooked**

6. Participants are not allowed to distribute any materials to the evaluators unless the event rules specifically allow it. Evaluators are not allowed to keep any items given to them by STAR Events participants.
7. No projects can be entered in more than one category of a single event, or in more than one event. However, projects entered in any event may be included in the Chapter in Review events.
8. Chapters are allowed to enter only one entry in Chapter in Review Display and Chapter in Review Portfolio per category.

# STAR Events

## Tips and Tricks

---

### **Eligibility and General Rules... Often Overlooked**

9. Chapters are allowed to enter only one entry in FCCLA Chapter Website.

10. Spectators are not allowed to observe any portion of any STAR Event. Videotaping and/or audio recording of events is not allowed.

11. Participants are to maintain a professional appearance and attitude during all STAR Events activities.



# STAR Events

## Tips and Tricks

---

### **Eligibility and General Rules... Often Overlooked**

12. Participants are responsible for their own event materials, and may not have others assist them with event setup, including moving items into the competition area.

Any items left behind are not the responsibility of FCCLA and may be discarded.

13. STAR Events resources (topics, scenarios, templates, etc.) can be found online on the national website.

# STAR Events

## Tips and Tricks

---

### **Eligibility and General Rules... Often Overlooked**

14. For Fashion Construction, Fashion Design and Recycle and Redesign, lingerie and swimsuits are not allowed. Clothing that does not meet acceptable standards of modesty/appropriateness for a school function or setting is prohibited.

# STAR Events

## Tips and Tricks

---

### **Eligibility and General Rules... Often Overlooked**

15. If a participant fails to adhere to event guidelines or event definition, or prepares an item not based on the current event scenario, then the sample/display/project is ineligible for evaluation. The participant will still be able to compete with an oral presentation if they choose to do so, and will only be scored on the oral presentation.

# STAR Events

## Tips and Tricks

---

### **Eligibility and General Rules... Often Overlooked**

16. Participants may present in front, behind, or beside the designated table or space. Participants may not place items on the consultant or evaluator tables.

17. All materials on displays must be placed on a clearly defined presentation surface. Displays with a clearly defined front presentation surface (such as tri-fold boards) may not have items on the back of the board, as consultants/evaluators would not be expected to look behind a display for project components. Displays with multiple presentation sides may have materials on all clearly defined presentation surfaces. All materials must be easily viewed, accessible, and legible.



# STAR Events Tips and Tricks

---

## **STAR Event Orientations**

- Online Orientation is for Nationals **ONLY**
- Onsite Orientation is **REQUIRED** at **REGION** and **STATE**



# STAR Events

## Tips and Tricks

---

### **Online Project Summary Forms**

- Located in the “Surveys” tab of the FCCLA Portal
- Required for at least one member on the team to complete
- Email confirmation – print out and sign

# STAR Events Tips and Tricks

---

## Online Project Summary Forms

**From:** FCCLA <[noreply@registernvchapter.com](mailto:noreply@registernvchapter.com)>  
**Date:** January 16, 2018 at 3:37:32 PM EST  
**To:** [sampleemail@yahoo.com](mailto:sampleemail@yahoo.com)  
**Subject:** STAR Events Project Summary  
**Reply-To:** [competitiveevents@fcclainc.org](mailto:competitiveevents@fcclainc.org)

### EVIDENCE OF PROJECT SUMMARY SUBMISSION

Thank you for completing the project summary form for your STAR Event. To receive the point for submission, print this email and have your adviser verify by signing and dating below for inclusion in a display, file folder, or portfolio.

Chapter Name: Sample Chapter

State: Sample

Members: Sample Student

Event Name: Advocacy

Category: Senior

Project Title: Sample Project Title

Adviser's Signature \_\_\_\_\_

Date \_\_\_\_\_

# STAR Events Roundtables

---

Learn more about specific events!